

Safety Guidelines for Land Transport of International Maritime Container

June 2013

June 2016 (Revision)

**Committee of Safety Land Transport Policy
for International Maritime Container**

Contents

Introduction	1
1. Background	2
2. Purpose of the Guidelines	3
3. Definitions	3
4. Scope of the Guidelines	4
5. Outline	4
(1) Outline of the Contents	4
(2) Stakeholders and Their Roles in a Safe Container Transport	5
6. How to Use the Guidelines	5
7. Content	6
(1) Efforts to be Made by Consignees (Importers)	6
(2) Efforts to be Made by Consignors (Exporters)	7
(3) Efforts to be Made by Shipping Companies	8
(4) Efforts to be Made by Terminal Operators	9
(5) Efforts to be Made by Intermediary Agents and Others	10
(6) Efforts to be Made by Trucking Companies	11
(7) Efforts to be Made by Drivers	13
Conclusion	14
Reference Materials	15

Introduction

On August 9, 2005, in response to the "Policy Package for Realizing Safe and Efficient International Logistics" established in March 2005, seven ministries and agencies including the Ministry of Land, Infrastructure, Transport, and Tourism established the "Committee for Promotion of Safe and Efficient International Logistics Policies" and the "Working Group on Safe Land Transport of International Maritime Containers" under the said committee. Under this Working Group, the first edition of "Safety Guidelines for Land Transport of International Maritime Container" was formulated.

The first edition of the guidelines, which were formulated in December 2005, provide specific measures to be taken by shippers, ship operators, terminal operators, intermediary agents and others (intermediary agents, maritime cargo handling companies, and consigned freight forwarders), trucking companies, and drivers to strengthen measures for safe land transportation of international maritime containers. However, as the Ministry of Land, Infrastructure, Transport and Tourism conducted technical studies through demonstration experiments and surveys on the actual conditions of container information transmission under the "International Maritime Container Truck Accident Prevention Promotion Project" from 2010 to 2012, certain views were obtained regarding the principles of container trailer rollover and various measures based on the actual practices of container information declaration process. From these findings, the contents of this guideline are reviewed and summarized thoroughly.

Committee of Safety Land Transport Policy for International Maritime Container, 2013

1. Background

International maritime containers currently occupy a central position in international logistics because of their ability to provide efficient intermodal transportation by sea and land, becoming increasingly important in Japan's logistics. However, in the truck transportation of international maritime containers, in addition to the problems of accidents caused by the operation of the truck such as overspeed and failure of container locks, the unique characteristic of container transport where cargo is transported in sealed containers and therefore drivers cannot fully grasp the state of the cargo inside the containers, makes it difficult to grasp the information about the weight, item, and stowage of the cargo inside the containers. Even if an unsafe container is found, it is difficult for on-site workers and drivers to make decisions on their own due to difficulties in reaching a consensus among the parties involved regarding on-site responses.

On the other hand, since it is difficult to obtain accurate information about import containers that are packed by foreign shippers, international rules have been developed for the communication of container information. For example, the revision of the SOLAS Convention (International Convention for the Safety of Life at Sea) has been discussed regarding the transmission of the weight of each container, and the "Guidelines for Packing of Cargo Transport Units" was revised and clarification of the role of the entire supply chain has been discussed at the expert meetings hosted by IMO, ILO, and UNECE.

In addition, to encourage drivers to drive safely, the "International Maritime Container Truck Accident Prevention Promotion Project" has been conducting studies for three years since 2010 based on demonstration experiments to derive guidelines for safe speeds and unbalanced loads that should be corrected according to road conditions and load weights. Also, a survey was conducted on the methods of reliable information transmission among the organizations involved in the transportation of international maritime containers, procedures for detecting and correcting containers in inappropriate conditions such as overweight and unbalanced loads, and proper stowage methods to avoid unbalanced loads, resulting in the compilation of the "Safety Manual for Land Transport of International Maritime Container" in 2012.

Based on these international trends and the results of the three-year study, in order to promote safety measures for land transportation of international maritime containers, the mechanisms for reliable information transmission and measures to detect and correct inappropriate containers were reexamined and this guideline, which were formulated in December 2005, were revised.

2. Purpose of the Guidelines

In order to strengthen measures for the safety land transport of international maritime containers, guidelines were created on measures to be taken by shippers, ship operators, terminal operators, intermediary agents and others (intermediary agents, maritime cargo handling companies, and consigned freight forwarders), trucking companies, and drivers.

For specific details mentioned in this guideline, please refer to the "Safety Manual for Land Transport of International Maritime Container."

3. Definitions

- Consignee: An entity that receives the international maritime container at its final destination. However, in cases where the said entity does not arrange the land transport of the import container to the final destination, the entity indicated as the consignee in the maritime transportation contract document issued by the shipping company shall play the role of the consignee.
- Consignor: An entity that loads cargo into the international maritime container at the point of departure.
- Shipper: An entity that is described as the shipper in the maritime transportation contract documents.
- Intermediary services: Intermediary services for the transportation of cargo carried out by a freight forwarder under its own name, or consignment of transportation of cargo to a freight forwarder under the name of another entity.
- Intermediary agent: An entity that provides intermediary services.
- Maritime cargo handling company: A business operator that consistently performs coastal cargo handling and barge transportation of individual cargoes at a port under consignment from shippers. The operator must comply with the general port and harbor transportation businesses stipulated in the Port and Harbor Transportation Business Act.
- Freight forwarder: A consigned freight forwarder based on the Consigned Freight Forwarding Business Act and Motor Truck Transportation Business Act.
- Intermediary agent and others: An intermediary agent, maritime cargo handling company, and freight forwarder.
- Trucking company: A General Motor Truck Transportation Business Operator, or a Special Motor Truck Transportation Business Operator as stipulated in the Motor Truck Transportation Business Act.
- Driver: A person who transports international maritime containers under a trucking company.
- Shipping company: A ship operator based on the Maritime Transportation Act.
- Terminal operator: An entity that operates a port terminal facility for containers handling.
- Inappropriate container: A container in a condition that may interfere with safe transport of the container truck, such as overweight and unbalanced load.
- Overweight: A condition in which the weight of a vehicle or container exceeds the weight limit

specified in the relevant laws and regulations (e.g., violation of the Road Traffic Act (overload), violation of the Vehicle Restriction Order, and exceeding the maximum load weight of the container).

- Unbalanced load: A condition in which the center of gravity of the load on the motor truck is deviated from the center.
- Correction: Unloading or reloading cargo an inappropriate containers at an appropriate location.
- B/L and other documents: bill of lading (B/L), waybill, arrival notice (A/N), invoice (I/V), packing list (P/L), or other documents containing information equal to or greater than that contained in the bill of lading.
- Dangerous goods: Dangerous goods specified in the United Nations Recommendations on the Transport of Dangerous Goods (UN Recommendations), including not only hazardous materials under the Fire Service Act, but also poisonous and deleterious substances under the Poisonous and Deleterious Substances Control Act and high-pressure gases under the High Pressure Gas Safety Act.

4. Scope of the Guidelines

This guideline suggests practices to identify containers that are in an inappropriate condition, such as overweight or unbalanced load, or that which would violate laws and regulation, then suggests method to improve such conditions. For detailed practices, please refer to the "Safety Manual for Land Transport of International Maritime Container."

In addition to the practices described in these guidelines and the manual, it is necessary to take appropriate action to avoid violating applicable laws and regulations.

5. Outlines

(1) Outline

- 1) Safe driving of a truck
 - Driving at safe speeds with proper maneuvers
 - Thoroughly locking tightening devices, etc.
- 2) Communication of container information
 - Report weight, item, packing style, etc.
 - Report information on dangerous goods, etc.
- 3) Measures to detect and correct inappropriate containers
 - Document check before entering the port
 - Detection and correction of inappropriate containers on-site after entering the port
- 4) Cargo packing
 - For import containers, requests to consignors for proper packing
 - For export containers, proper packing before transporting the cargo

(2) Stakeholders and their roles in a safe container transport

Each party involved in the intermodal transport of international maritime containers are responsible for their roles listed in the table below.

	1) Safe driving of truck	2) Communication of container information	3) Measures to detect and correct inappropriate containers	4) Cargo packing	
				Import containers	Export containers
(1) Consignee	✓	✓	✓	✓	-
(2) Consignor	✓	✓	-	-	✓
(3) Shipping company	-	✓	✓	-	-
(4) Terminal operator	-	✓	✓	-	-
(5) Intermediary agent and others	✓	✓	✓	-	-
(6) Trucking company	✓	✓	✓	-	-
(7) Driver	✓	-	✓	-	-

6. How to Use the Guidelines

1) Thorough dissemination and follow-up of the guidelines

- The "Regional Committee of Safety Land Transport Policy for International Maritime Container" will be established to confirm the matters to be addressed by the parties involved with regard to the contents of these guidelines and manuals.
- A follow-up study will be conducted by the relevant organizations on the status of recognition and implementation of these guidelines and manuals.
- The parties involved in the land transportation of international maritime containers shall make efforts to ensure that each party has a common understanding of these guidelines and manuals.

2) Pilot operation by the Model Detection and Correction Working Group

- The "Working Group for Model Operation of Detection and Correction for Inappropriate Containers" (hereinafter referred to as the "Working Group") will be established by the parties involved at major ports to develop detection and correction according to the facilities at the port.
- Based on the detection and correction procedures developed by the Working Group, detection and correction measures will be taken, then follow-up on the implementation status will be conducted.

3) Revision of guidelines and manuals based on follow-up results

- The guidelines and manuals shall be revised as necessary based on the results of 1) and 2).

7. Contents

(1) Efforts to be Made by Consignees

Guideline	
1) Safe driving of truck	[See 5. (1) of the Safe Transportation Manual.]
Transportation request considering the extra time needed for transportation	<ul style="list-style-type: none"> ○ Be aware that container trailers can roll over even at a lower speed. Thus, it is suggested that a request for transportation should be made by considering the extra time needed for transportation, assuming that the trailer will travel at a very low speed.
2) Communication of container information	[See 5. (2) of the Safe Transportation Manual.]
Communication of information to the intermediary agent or the like about weight, item, packing, etc.	<ul style="list-style-type: none"> ○ Make sure to communicate information about the weight, item, and packing of cargo in the container, as well as information about dangerous goods, to the intermediary agent and others using B/L or other necessary documents. ○ When requesting land transportation of international maritime containers directly from a trucking company, provide information in Japanese about the weight, item, and packing of the cargo in the container, as well as information about dangerous goods, to the trucking company. ○ If the tare weight of the container is known in advance, such information should be provided to the trucking company (via an intermediary agent). ○ If there is an inquiry from the trucking company or other parties involved about the contents of the container (including any exterior abnormalities), every known information should be provided.
Communication of information about dangerous goods	<ul style="list-style-type: none"> ○ In addition to the item name of the contents of the container, information about dangerous goods such as types, quantities, and yellow cards should be communicated to the intermediary agent and others.
3) Measures to detect and correct inappropriate containers	[See 5. (3) of the Safe Transportation Manual.]
Document check before entering the port	<ul style="list-style-type: none"> ○ In order to perceive inappropriate containers based on documents, check necessary information such as the weight, item, and packing style of the containers.
Detection and correction of inappropriate containers on-site after entering the port	<ul style="list-style-type: none"> ○ If informed by a shipping company or an intermediary agent and others that the container arriving at the terminal is an inappropriate container, coordinate in advance with the terminal operator (via the shipping company) and the trucking company (via the intermediary agent) on the appropriate action to be taken, such as opening the container and reloading the container. ○ If informed by a terminal operator (via a shipping company) or a trucking company (via an intermediary agent) when carrying out the container that overweight, unbalanced load, high center of gravity, damage to the container, leakage of contents, or other problems are found, contact the shipper and ask for instructions on appropriate action such as opening and repacking, and then take appropriate action based on the instructions.

4) Cargo packing	[See 5. (4) of the Safe Transportation Manual.]
For import containers, requests to consignors for a proper packing	<ul style="list-style-type: none"> ○ Educate consignors on proper stowage in the container based on cargo characteristics. Also, as stowage instructions, ask the consignor to consider the characteristics and packing specifications of the cargo when stowing. ○ If the consignee has received a container with unbalanced load, load collapse, or unsecured cargo from the same consignor in the past, the consignee should remind the consignor of such concerns. ○ For safe transportation of the containers, request even consignors in non-SOLAS Convention countries to provide information about the weight of each container.

(2) Efforts to be Made by Consignors

Guideline	
1) Safe driving of truck	[See 5. (1) of the Safe Transportation Manual.]
Transportation request considering the extra time needed for transportation	<ul style="list-style-type: none"> ○ Be aware that container trailers can roll over even at a lower speed. Thus, it is suggested that a request for transportation should be made by considering the extra time needed for transportation, assuming that the trailer will travel at a very low speed.
2) Communication of container information	[See 5. (2) of the Safe Transportation Manual.]
Communication of information to the intermediary agent or the like about weight, item, packing, etc.	<ul style="list-style-type: none"> ○ Make sure to communicate information about the weight, item, and packing of cargo in containers, as well as information about dangerous goods, to the intermediary agent or the like using a bill of lading (B/L), packing list (P/L), and other necessary documents. ○ When requesting land transportation of international maritime containers directly from a trucking company, provide information in Japanese about the gross weight, item, and packing of the container, as well as information about dangerous goods, to the trucking company. ○ If there is an inquiry from the trucking company or other parties involved about the contents of the container (including any exterior abnormalities), known information should be provided.
Communication of information about dangerous goods	<ul style="list-style-type: none"> ○ In addition to the item name of the contents of the container, information about dangerous goods such as types, quantities, and yellow cards should be communicated to the intermediary agent and others.
4) Cargo packing	[See 5. (4) of the Safe Transportation Manual.]
For export containers, proper pack before transport the cargo	<ul style="list-style-type: none"> ○ Consider the characteristics and packing specifications of the cargo when packing.

(3) Efforts to be Made by Shipping Companies

Guideline	
2) Communication of container information	[See 5. (2) of the Safe Transportation Manual.]
Communication of information to the intermediary agent or the like about weight, item, packing, etc.	○ If there is an inquiry from the shipper, terminal operator, or other parties involved about the contents of the container, known information should be provided.
Communication of information about dangerous goods	○ If any abnormality, such as leakage of dangerous goods from the container, is found, immediately notify the shipper and other parties involved.
3) Measures to detect and correct inappropriate containers	[See 5. (3) of the Safe Transportation Manual.]
Detection and correction of inappropriate containers on-site after entering the port	<ul style="list-style-type: none"> ○ If overweight (exceeding the maximum load weight of the container), unbalanced load, high center of gravity, damage to the container, leakage of contents, or other problems are found at the overseas origin, the shipping company should contact the shipper and request pickup. ○ If overweight (exceeding the maximum load weight of the container), unbalanced load, high center of gravity, damage to the container, leakage of contents, or other problems are found prior to entering the port, the shipping company should contact and coordinate with the shipper and terminal operator in advance so that appropriate action can be taken. ○ If informed at the terminal after entering the port by the terminal operator about overweight (exceeding the maximum load weight of the container), unbalanced load, high center of gravity, damage to the container, leakage of contents, or other problems, the shipping company should contact and coordinate with the shipper so that appropriate action can be taken.
4) Cargo packing	[See 5. (4) of the Safe Transportation Manual.]
Education of consignors	○ Educate consignors on proper stowage in containers to avoid unbalanced loads and damage to the container.

(4) Efforts to be Made by Terminal Operators

Guideline	
2) Communication of container information	[See 5. (2) of the Safe Transportation Manual.]
Communication of information to the intermediary agent or the like about weight, item, packing, etc.	○ If there is an inquiry from a party involved about the contents of the container, known information should be provided.
Communication of information about dangerous goods	○ If any abnormality, such as leakage of dangerous goods from the container, is found, immediately notify the shipper and other parties involved via the shipping company.
3) Measures to detect and correct inappropriate containers	[See 5. (3) of the Safe Transportation Manual.]
Detection and correction of inappropriate containers on-site after entering the port	<ul style="list-style-type: none"> ○ If informed by the shipping company or others that there is a risk of overweight (exceeding the maximum load weight of the container), unbalanced load, high center of gravity, damage to the container, leakage of contents, or other problems, follow their instructions and take appropriate action. ○ If overweight (exceeding the maximum load weight of the container), unbalanced load, high center of gravity, damage to the container, leakage of contents, or other problems are found at the terminal after entering the port, the terminal operator should contact and coordinate with the shipping company so that appropriate action can be taken. ○ If informed by the truck driver when carrying out the container that overweight, unbalanced load, high center of gravity, damage to the container, leakage of contents, or other problems are found, contact the shipper via the shipping company and ask for instructions on appropriate action such as opening and repacking, and then take appropriate action based on the instructions.

(5) Efforts to be Made by Intermediary Agents and Other

Guideline	
1) Safe driving of truck	[See 5. (1) of the Safe Transportation Manual.]
Transportation request considering the extra time needed for transportation	<ul style="list-style-type: none"> ○ Be aware that container trailers can roll over even at a lower speed. Thus, it is suggested that a request for transportation should be made by considering the extra time needed for transportation, assuming that the trailer will travel at a very low speed.
Precautions for transporting dangerous goods	<ul style="list-style-type: none"> ○ Confirm the laws and regulations related to dangerous goods in advance and comply with them.
2) Communication of container information	[See 5. (2) of the Safe Transportation Manual.]
Communication of information to the intermediary agent or the like about weight, item, packing, etc.	<ul style="list-style-type: none"> ○ When a request for transportation intermediary services is received from the consignee or the consignor, make sure to obtain information about the weight, item, and packing of cargo in containers, as well as information about dangerous goods, from a bill of lading (B/L), packing list (P/L), and other necessary documents. ○ Communicate the container information in documents written in Japanese to the trucking company. In addition, instruct the trucking company to ensure that drivers receive thorough instructions and precautions. ○ If the tare weight of the container is known in advance, it should be communicated to the trucking company. ○ If there is an inquiry from the trucking company or other parties involved about the contents of the container (including any exterior abnormalities), known information should be provided.
Communication of information about dangerous goods	<ul style="list-style-type: none"> ○ In addition to the item name of the contents of the container, information about dangerous goods such as types, quantities, and yellow cards should be communicated to the trucking company.
3) Measures to detect and correct inappropriate containers	[See 5. (3) of the Safe Transportation Manual.]
Document check before entering the port	<ul style="list-style-type: none"> ○ In order to perceive inappropriate conditions, such as overweight or unbalanced load, based on documents, check necessary information such as the weight, item, and packing of the containers.
Detection and correction of inappropriate containers on-site after entering the port	<ul style="list-style-type: none"> ○ If informed by the shipper or others in advance that there is a risk of overweight, unbalanced load, high center of gravity, damage to the container, leakage of contents, or other problems, follow their instructions and take appropriate action to avoid violating applicable laws and regulations. ○ If informed by the trucking company when carrying out the container that overweight, unbalanced load, high center of gravity, damage to the container, leakage of contents, or other problems are found, contact the shipper and ask for instructions on appropriate action such as opening and repacking, and then take appropriate action based on the instructions.

(6) Efforts to be Made by Trucking Companies

Guideline	
1) Safe driving of truck	[See 5. (1) of the Safe Transportation Manual.]
Instructions to ensure transportation at safe speeds	○ Semi-trailers are heavier than regular trucks and have a higher center of gravity, so instruct drivers to drive at a lower speed than regular trucks, and to slow down at curves and intersections.
Prevention of overweight	○ Based on the information obtained from the consignee or the intermediary agent and others, grasp the gross weight of the containers and allocate vehicles to avoid being overweight.
Carrying a special vehicle permit	○ Do not load international maritime containers on vehicles that do not carry a special vehicle permit.
Precautions for transporting dangerous goods	○ Prepare for compliance with laws and regulations related to dangerous goods, and inform drivers of the laws and regulations related to dangerous goods to ensure compliance with such laws and regulations.
Others	○ Provide sufficient education to drivers about the characteristics of vehicles when transporting international maritime containers.
2) Communication of container information	[See 5. (2) of the Safe Transportation Manual.]
Communicating information about weight, item, packing, etc. to drivers	○ Communicate to the driver the information obtained from the shipper (via the intermediary agent) about the weight, item, packing, and others of the cargo in the container, as well as information about dangerous goods, and if necessary, instruct the driver to visually check the tilt of the rear of the container and measure the tilt. ○ If the tare weight of the container cannot be obtained from the shipper (via the intermediary company), the tare weight of the container should also be communicated to the driver.
Communication of information about dangerous goods	○ In addition to the item name of the contents of the container, information about dangerous goods such as types, quantities, and yellow cards should be communicated to the driver.
3) Measures to detect and correct inappropriate containers	[See 5. (3) of the Safe Transportation Manual.]
Document check before entering the port	○ If the information obtained from the shipper (via the intermediary agent) indicates that there is a risk of overweight, unbalanced load, high center of gravity, damage to the container, leakage of contents, or other problems, contact the shipper and ask for instructions on how to respond. ○ If informed by the shipper (via the intermediary agent) that there is a risk of overweight, unbalanced load, high center of gravity, damage to the container, leakage of contents, or other problems, follow the shipper's instructions (via the intermediary agent) and take appropriate action to avoid violating applicable laws and regulations.

<p>Detection and correction of inappropriate containers on-site after entering the port</p>	<ul style="list-style-type: none">○ If it is known in advance that there is a risk of overweight, unbalanced load, high center of gravity, damage to the container, leakage of contents, or other problems in the container yard, or if informed by the driver to that effect when carrying out the container, contact the intermediary agent or the like and ask for instructions.○ If there is a risk of unbalanced load or other problems that may interfere with safe transportation, contact the intermediary agent or the like to that effect and do not allow the container to be carried out until it is in a condition that does not conflict with applicable laws and regulations.○ If informed by the driver that there is a risk of overweight, weigh the container as necessary according to the instructions of the consignee (or the intermediary agent or the like). Then if overweight is found, carry out the container after it is in a condition that does not conflict with applicable laws and regulations.
---	---

(7) Efforts to be Made by Drivers

Guideline	
1) Safe driving of truck	[See 5. (2) of the Safe Transportation Manual.]
Driving at a safe speed	○ Semi-trailers are heavier than regular trucks and have a higher center of gravity, so instruct drivers to drive at a lower speed than regular trucks, and to slow down at curves and intersections.
Prevention of overweight	○ Grasp the weight information of the container based on the information obtained from the trucking company. If the weight information does not include the tare weight of the container, check the tare weight indicated on the container and confirm that the gross weight including the actual tare weight is not overweight before carrying out the container.
Confirmation of transportation route	○ The driver should confirm the route to the designated delivery destination from the special vehicle permit and should carry the permit.
Checking container tilt prior to transportation	○ Check the condition of the vehicle while driving at the terminal with the container loaded, and if necessary, visually check the tilt of the rear of the container and measure the tilt of the container.
Thorough locking tightening devices	○ Before carrying out the container, thoroughly lock tightening devices at the front, back, left, and right of the container.
Precautions for transporting dangerous goods	○ Confirm the laws and regulations related to dangerous goods in advance and comply with them. ○ Transporting dangerous goods using dry containers or other mobile tank storage facilities should be conducted by a person who are qualified by laws and ordinances related to dangerous goods, such as a hazardous materials engineer.
2) Communication of container information	[See 5. (2) of the Safe Transportation Manual.]
Communicating information about weight, item, packing, etc. to drivers	○ Before carrying out the container, check the information about the weight, item, and packing of the cargo in the container, as well as information about dangerous goods.
3) Measures to detect and correct inappropriate containers	[See 5. (3) of the Safe Transportation Manual.]
Detection and correction of inappropriate containers on-site after entering the port	○ If you notice from the behavior of the truck or other conditions that the weight of the container is obviously greater than the weight described in the document, contact the trucking company, and if necessary, weigh the container according to the company's instructions to ensure that it is not overweight before carrying it out. ○ If overweight, unbalanced load, high center of gravity, damage to the container, leakage of contents, or other problems are found, contact the trucking company and the terminal. ○ If there is a concern that any of the above problems may interfere with safe transportation, do not carry out the container. Inform the trucking company and the terminal to that effect and carry out the container only after it is in a condition that does not conflict with applicable laws and regulations.

Conclusion

In order to strengthen measures for a safety land transportation of international maritime containers, it is essential that those involved in the committee, related organizations, and related business operators share the awareness of ensuring the dissemination of these guidelines, and that practices mentioned in the guidelines are steadily implemented.

In addition, in order to further enhance the effectiveness of these guidelines, it is necessary to periodically monitor the implementation status of these guidelines and review the guidelines based on the opinions of the parties involved. It is also important to address the following issues in the future.

[Issue 1] Establish international rules for proper stowage and communication of cargo information

In order to prevent accidents induced by cargo in the land transportation of international maritime containers, it is essentially necessary to ensure that the consignor, who loads the containers, packs them properly and ensures that the stowage condition is communicated to the freight forwarder. Therefore, IMO, ILO, UNECE, and other organizations are currently discussing the revision of the international guidelines. Once the international guidelines are revised, it will be necessary to make them known not only to Japanese shippers but also to other countries so that they are thoroughly implemented.

[Issue 2] Explore more efficient ways to communicate information using information technology

A mechanism for communicating information through a system is currently being established at Nagoya Port and other ports. Therefore, it is necessary to study the actual conditions and explore a mechanism for more efficient and reliable communication of information.

APPENDIX

Appendix 1: List of Members of the Committee of Safety Land Transport Policy for International Maritime Containers	16
Appendix 2: Procedures and Documentation Flow for Importing International Maritime Containers	17
Appendix 3: Terminology Concerning International Maritime Containers	18
Appendix 4: Major Legal Provisions Concerning Land Transportation of International Maritime Containers	24
Reference 5: Statistics of Accidents in Land Transportation of International Maritime Containers	26

Appendix 1

List of Members of the Committee of Safety Land Transport Policy for International Maritime Containers

(In Japanese syllabary order, honorifics omitted)

Related industries

Toshio Asada	Business Manager, Japan International Freight Forwarders Association Inc.
Shoji Obara	Japan Harbor Transportation Association (Affiliation: General Manager, Harbor Transportation Business Division, Mitsubishi Logistics Corporation)
Masaya Sato	Chief, Industrial Policy Bureau, Keidanren (Japan Business Federation)
Yasushi Shigeno	Secretary, Logistics System Executive Committee, Japanese Shipowners' Association (Affiliation: Group Leader, Containerships Strategic Group, Kawasaki Kisen Kaisha, Ltd.)
Shigehisa Hashizume	Secretary General, Japan Institute of Logistics Systems
Naoyuki Hamada	Chairperson, Logistics Committee Working Group, Japan Foreign Trade Council, Inc. (Affiliation: Assistant to General Manager, Logistics Management Department, Sumitomo Corporation)
Katsushige Mashima	Deputy General Secretary, All Japan Dockworker's Union
Kazuhiko Miyazaki	Japan Foreign Steamship Association (Affiliation: Division Manager, A.S. Operation Division, A.P. Moller - Maersk)
Atsushi Yamamoto	Vice Chairman, Maritime Container Subcommittee, Japan Trucking Association (Affiliation: Managing Director, Meikai Unyu Sagyo Co., Ltd.)
Tatsuya Yamamoto	Chief Investigator, Distribution and Regional Development Department, Japan Chamber of Commerce and Industry
Masao Watanabe	Managing Director, Japan Freight Forwarders Federation

Ministry of Land, Infrastructure, Transport and Tourism

Akira Saka	Assistant Vice-Minister for Automobile, Minister's Secretariat, Ministry of Land, Infrastructure, Transport and Tourism
Akihiko Kanai	Director for Logistics Industries Affairs, Minister's Secretariat, Ministry of Land, Infrastructure, Transport and Tourism
Masafumi Mori	Director, Planning Division, Road Bureau, Ministry of Land, Infrastructure, Transport and Tourism
Hisashi Yoshitake	Director, Road Traffic Control Division, Roads Bureau, Ministry of Land, Infrastructure, Transport and Tourism
Toshihiro Matsumoto	Director for Safety Policy, Road Transport Bureau, Ministry of Land, Infrastructure, Transport and Tourism
Motoya Shimono	Director, Safety Policy Division, Road Transport Bureau, Ministry of Land, Infrastructure, Transport and Tourism
Ichiro Fujiwara	Director, International Affairs Office, Road Transport Bureau, Ministry of Land, Infrastructure, Transport and Tourism
Naoki Esumi	Director, Technology Policy Division, Road Transport Bureau, Ministry of Land, Infrastructure, Transport and Tourism
Itaru Kaga	Director, Cargo Transport Division, Road Transport Bureau, Ministry of Land, Infrastructure, Transport and Tourism
Tetsuro Hirata	Director, International Shipping Division, Maritime Bureau, Ministry of Land, Infrastructure, Transport and Tourism
Toshihiko Sonoda	Director, Inspection and Measurement Division, Maritime Bureau, Ministry of Land, Infrastructure, Transport and Tourism
Toru Kawaharabata	Director, Port Management and Operation Division, Ports and Harbours Bureau, Ministry of Land, Infrastructure, Transport and Tourism

Relevant ministries and agencies

Koichi Hirota	Director, Traffic Planning Division, Traffic Bureau, National Police Agency
Tatsuya Sago	Director, Distribution and Logistics Policy Division, Commerce Distribution and Industrial Safety Policy Group, Ministry of Economy, Trade and Industry

Secretariat: Safety Policy Division, Road Transport Bureau, Ministry of Land, Infrastructure, Transport and Tourism

Appendix 2

Procedures and Documentation Flow for Importing International Maritime Containers

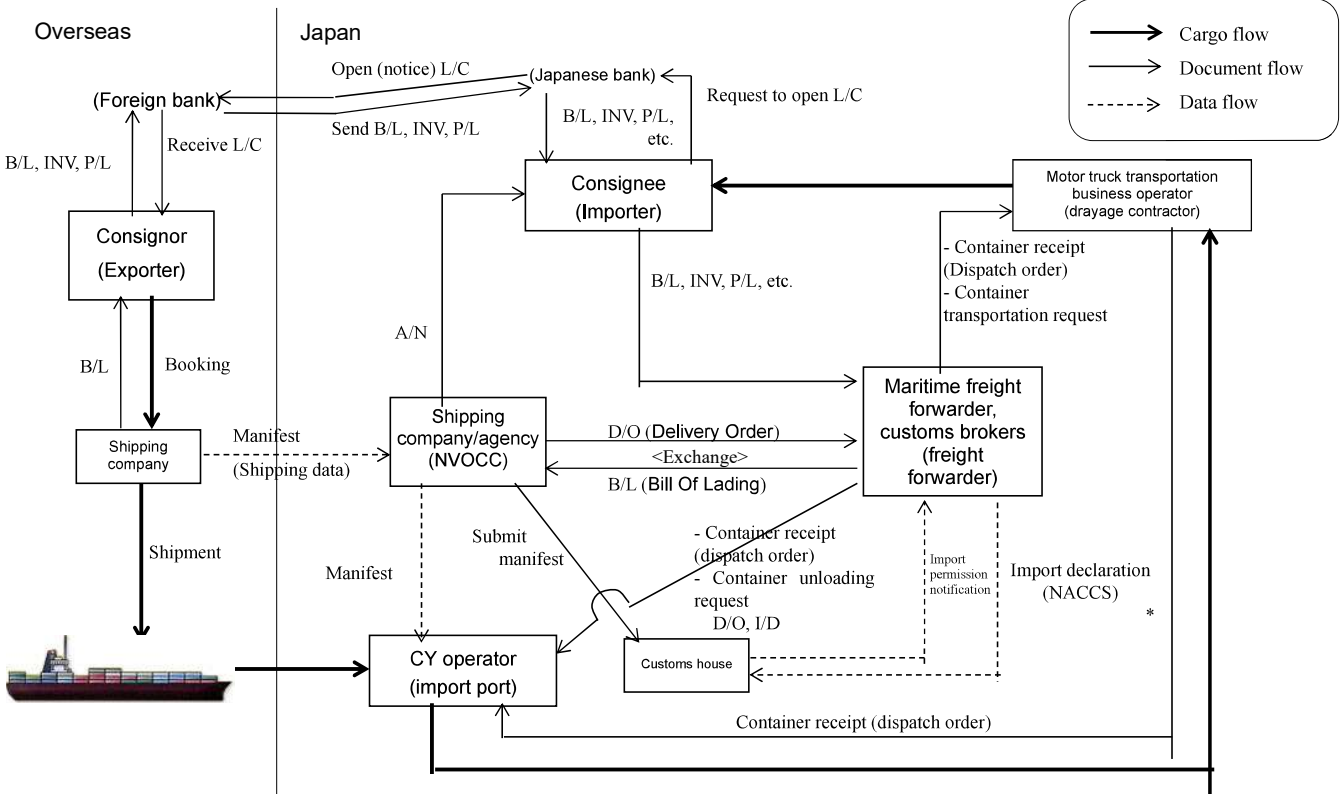

* Recently, I/D is often sent by NACCS.
 I/D: Import Declaration (Notice of Import Permit)
 The import declaration contains the importer's name, item, quantity, price, tariff, consumption tax, and so on. It is submitted to the customs office when the goods are imported, which becomes the notice of import permit when the customs office approves the import and issues it with a permit stamp.

Terminology Concerning International Maritime Containers

Arrival notice

A notice of arrival. A letter from the shipping company notifying the shipper of the scheduled arrival date of the ship, cargo details, and freight charges.

Invoice

A statement sent by the shipper to the consignee detailing the name, type, price, shipper, consignee, and other information about the shipped cargo.

Yellow card

An emergency contact card that describes the details of a dangerous cargo and the actions to be taken by transport personnel, firefighters, police, and related parties in the event of accident.

Otsunaka

A shipping cargo handler (maritime freight forwarder). Before World War II, Class A shipping brokers (chartering brokers) were abbreviated as "Ko-naka," while Class B brokers (brokers of carriage of goods in general ship) were abbreviated as "Otsunaka," and this is still used today as a common name for maritime freight forwarders. (Cf. Maritime freight business)

Maritime freight business

Maritime cargo handling business. A business operator that consistently performs coastal cargo handling and barge transportation of individual cargoes at a port under consignment from shippers, among the (first-class) general port and harbor transportation businesses stipulated in the Port and Harbor Transportation Business Act. New maritime freight business accepts consignments not only from shippers but also from shipping companies and is referred to as maritime freight business as well. (Cf. Otsunaka)

Maritime container

A box made of aluminum or steel for transporting cargo by ship. The dimensions are specified in ISO standards, and the main types are 8 feet or 8 feet 6 inches in height, and 20 feet and 40 feet in length. Containers with a length of 45 feet are also common in the United States. In recent years, the use of so-called tall containers with a height of 9 feet 6 inches has also increased. There are various types of containers, such as dry, bulk, and tank containers, which are used depending on the mode of transportation of the cargo. See "Container", "Tall container" and "Type of container" for more details.

Mixed loading

Collecting small packages from many customers and making them into a single transportation unit (e.g., cargo, truck, container, and pallet).

Consignee

A shipment receiver. (Ant. Shipper)

Container terminal

Maritime container transportation facilities consisting of quays, gantry cranes, container yards,

transfer cranes, container freight stations, control towers, and so on.

Container Freight Station

→ See “CFS (Container Freight Station)”

Container Load Plan

→ See “CLP (Container Load Plan)”

Container Yard

→ See “CY (Container Yard)”

Container

Generally refers to a shipping container for the purpose of unitizing cargo. For containers, the definition, main dimensions, maximum gross weight, and indication methods are internationally specified by ISO standards.

Sizes: 20 feet, 40 feet, etc.

Classification by intended use: Dry container, reefer container (refrigerated container), open top container, tank container, flat rack container, etc. (Cf. Special container)

→ See “Special container” for more details

Shipper

A shipment sender. (Ant. Consignee)

Shipping Instructions

Abbreviated as S/I. Instructions for B/L preparation. For example, when exporting with an L/C, the exporter must have a B/L that matches the contents of the L/C prepared by the shipping company. Otherwise, the buyer will not be able to purchase the goods. This document is used to instruct the shipping company on the contents of the B/L. If the instructions are incorrect, the contents of D/R, M/R, and B/L will not be consistent. This is one of the most important documents to be prepared by the shipper. Instructions for B/L preparation.

Tall container

A container that is taller than a regular container (8 feet or 8 feet 6 inches high). Also called "high cube."

Appendix 3

Terminal operator

An operating entity of a container terminal. In Japan, in addition to overseeing the entire container system at the port, the work is performed by a licensed operator (harbor transportation operator) under the Port and Harbor Transportation Business Act.

Tank container

A container equipped with a tank for transporting liquid cargo such as food, oil, and chemicals.

Custom-house broker

Also referred to as a customs broker or customs freight forwarder. An entity that handles customs clearance procedures related to the import and export of trade cargo on behalf of the shipper and has obtained a license from the competent tax authority having jurisdiction over the place of business. In many cases, a maritime freight forwarder, warehouse operator, or forwarding agent also serves as a custom-house broker.

Devanning

To remove cargo from a container. Also called unstuffing or unpacking. (Ant. Vanning)

Special container

Special containers other than dry cargo containers. They include refrigerated containers (reefer containers), flat rack containers, open top containers, flat head containers, bulk containers, tank containers, and pen containers.

Dry container

Typical containers, which account for an estimated 80% or more of all containers distributed worldwide.

Packing style

A form of external packing applied to cargo.

Consignor

An entity that has legal ownership of the cargo subject to logistics.

Cargo handling

To load and unload cargo.

Delivery order

→ See D/O (Delivery Order)

Appendix 3

Vanning

To stuff or pack cargo into a container. Also called stuffing or packing. (Ant. Devanning)

Freight forwarder

Generally means a forwarding agent.

Combined transport, intermodal/multimodal transport

A term that has come into common use through the draft convention on international multimodal transportation, which refers to cases where a particular consignment is carried by two or more different types of means of transportation. It is also referred to as intermodal transportation, emphasizing the consistency of its transportation.

Bill of Lading

→ See B/L (Bill of Lading)

Bonded transportation

A form of bonded system. To complement or facilitate the use of bonded areas, foreign goods may be transported between bonded areas in a bonded state, subject to customs office approval. (Cf. OLT)

Main ship

Refers to ocean-going vessels as opposed to barges, tugboats, and other harbor transport ships.

Manifest

A list of cargoes that describes cargo details, consignees, and so on, by port of loading, port of discharge, and bill of lading number. A document required for customs clearance. The customs office at the port of discharge of each country requires the manifest, signed by the captain, to be submitted when the ship enters the port, and carries out the control and taxation of the cargo.

Loaded container

A container loaded with cargo.

Prime contractor

A general port and harbor transportation business operator under the Port and Harbor Transportation Business Act.

Appendix 3

Drayage

To move containers or cargoes placed at a specific location to another CY, shed, warehouse, etc., or to move them from a CY, shed, warehouse, etc. to the quay for the main ship or terminal.

B/L (Bill of Lading)

A document issued by a carrier (usually a shipping company) to a shipper to certify the shipment of cargo. It is a receipt for cargo, evidence of a transportation contract, and also has the character of a bill of delivery.

CFS (Container Freight Station)

Facilities for delivery, storage, loading, and unloading of LCL cargo.

CLP (Container Load Plan)

Refers to a container stowage list for vanned cargo. It is prepared for each container and submitted to the operator at the time of carrying into the yard, and is widely used for the stowage plan on the main ship, as well as transportation procedures and devanning operations at the port of discharge.

CY (Container Yard)

A place where FCL cargo is picked up, stored, and warehoused, or where empty containers are received and delivered.

D/O (Delivery Order)

A non-circulating document addressed by the shipping company to the CFS or CY operator, instructing to deliver the cargo to the bearer of this letter. Although cargo should originally be delivered in exchange for the B/L, in practice, the shipping company issues and delivers a D/O in response to the B/L submitted by the consignee, and the consignee presents the D/O to actually receive the delivery.

EDI (Electronic Data Interchange)

The direct exchange of data related to business processes, commercial transactions, and so on between different users' computers under widely agreed standard rules.

EDO (Equipment Despatch Order)

A container equipment delivery order. It is issued by a shipping company to a CY operator when a container is leased to a shipper. It indicates the vaning location, the location of the delivery CY, the return location of the container, and so on.

L/C (Letter of Credit)

A type of letter of guarantee issued by a bank at the request of an importer to guarantee payment for the cargo it imports. L/C settlement is currently the most widely used means of secure and prompt payment collection in trade transactions.

LCL (Less than Container Load)

Small cargo that is not enough to fill one container.

NACCS (Nippon Air Cargo Clearance System)

An air cargo customs clearance information processing system. First introduced at Narita International Airport in August 1978. The system further expanded to Osaka International Airport in October 1980. A system that automatically processes customs clearance and related operations by connecting the computers of the Nippon Air Cargo Clearance System Operations Organization in Nakano, Tokyo with customs offices, airlines, banks, freight forwarders, and other entities online.

NVOCC (Non Vessel Operating Common Carrier)

An entity that does not own a vessel or other means of transportation, but uses the services of an actual freight forwarder, such as a maritime freight forwarder, for transportation. It is responsible for transportation and tariffs in its own name. Freight forwarders often enter the NVOCC business, and in Japan, this is the case for consigned freight forwarders.

OLT (Overland Transport)

Bonded land transportation. This is a form of bonded transportation permitted under Japan's Customs Act, and refers to the transportation of foreign cargo between designated bonded areas by truck or rail. Permission is obtained from the customs office in the country of origin for a specified area and period of time.

SEA-NACCS (SEA-NIPPON Automated Cargo Clearance System)

A maritime cargo customs clearance information processing system. An online system that connects customs offices, freight forwarders, and banks to automatically process customs clearance and customs duty payments for maritime cargo. Started operation at Keihin Port in October 1991. Started operation at Hanshin and Nagoya ports in October 1992.

Reference: Yokohama City Port and Harbor Bureau Website

Appendix 4

Major Legal Provisions Concerning Land Transportation of International Maritime Containers

(1) Operation Control (Prevention of Overload, etc.)

Overload	1) Article 47 of the Road Act (Restrictions on Vehicle Traffic) [Ministry of Land, Infrastructure, Transport and Tourism]
	2) Article 42 of the Road Transport Vehicle Act (Seating Capacity or Maximum Load Capacity) [Ministry of Land, Infrastructure, Transport and Tourism]
	3) Article 57 of the Road Traffic Act (Restrictions on Riding and Loading; Related Considerations) [National Police Agency]
	4) Article 22 of the Order for Enforcement of the Road Traffic Act (Restrictions on Riding or Loading Vehicles) [National Police Agency]
	5) Article 58-5 of the Road Traffic Act (Prohibition on Requiring or Otherwise Compelling Drivers to Drive Overloaded Vehicles) [National Police Agency]
	6) Article 17 of the Motor Truck Transportation Business Act (Ensure Safety of Transportation) [Ministry of Land, Infrastructure, Transport and Tourism]
	7) Article 4 of the Motor Truck Transportation Business Transport Safety Regulations (Prevention of Overload) [Ministry of Land, Infrastructure, Transport and Tourism]
Load	6) Article 17 of the Motor Truck Transportation Business Act (Ensure Safety of Transportation) [Ministry of Land, Infrastructure, Transport and Tourism]
	8) Article 8 of the Motor Truck Transportation Business Transport Safety Regulations (Records of Crew Rides, etc.) [Ministry of Land, Infrastructure, Transport and Tourism]

(2) Packing (Loading Method and Prevention of Unbalanced Load)

- 1) Article 17 of the Motor Truck Transportation Business Act (Ensure Safety of Transportation) [Ministry of Land, Infrastructure, Transport and Tourism]
- 2) Article 5 of the Motor Truck Transportation Business Transport Safety Regulations (Method of Loading Cargo) [Ministry of Land, Infrastructure, Transport and Tourism]

(3) Cargo Contents (Safe Transportation of Dangerous Goods and Disclosure of Contents)

- 1) Fire Service Act [Fire and Disaster Management Agency]
 - Article 10 of the Act (Handling of Hazardous Materials of the Designated Quantity or a Larger Quantity)
 - Article 13 of the Act, Article 58-14 of the Regulations (Hazardous Materials Engineers)
 - Article 16-2 of the Act (Ride of a Hazardous Materials Engineer)
 - Article 16-3 of the Act (Response in the Event of an Accident)
 - Article 21-2 of the Act, Article 47 of the Safety Standards (Inspection of the Machine or Tool, etc. Subject to Inspection): Installation of Prescribed Fire Extinguishers According to Quantity
 - Cabinet Order and Regulations Concerning the Control of Hazardous Materials

Article 15 of the Order (Standards for Mobile Storage Tank Facilities): Indication of the Class, Name, and Maximum Quantity of Hazardous Materials
Article 15 of the Order, Article 17 of the Regulations (Posting Signs on the Front and Rear of the Vehicle)
Article 20 of the Order, Articles 32 and 35 of the Regulations (Standards for Fire Extinguishing Systems)
Article 25 of the Order (Standards for Storage and Handling of Hazardous Materials)
Article 26 of the Order (Standards for Storage): Always Carrying the Completion Inspection Certificate for the Lorry
Article 27 of the Order, Article 49-6 of the Regulations (Standards for Handling): Injection of Liquid Hazardous Materials that may Cause Static Electricity Hazards, Injection of Hazardous Materials with a Flash Point of Lower than 40 Degrees Article 27 of the Order: Engine Shutdown when Injecting Hazardous Materials with a Flash Point of Lower than 40 Degrees Article 27 of the Order, Article 40-5 of the Regulations: Tightening Injection Hoses from

Appendix 4

Lorries to Other Tanks
Article 27 of the Order, Article 40-6 of the Regulations: Grounding of Mobile Storage Tanks
Article 30-2 of the Order, Article 47-2 of the Regulations (Transportation Method): Securing Alternate Driving Personnel by Distance Note) Applicable to hazardous materials other than those specified by the Ordinance of the Ministry of International Affairs and Communications. Article 30-2 of the Order (Transfer Standards): Inspection of Valves, etc. before Operation, Safe Parking Location, and Emergency Response
Article 24-5 of the Regulations (Prescribed Indication on Tank Containers)

2) High Pressure Gas Safety Act [Ministry of Economy, Trade and Industry]

- Article 23 of the Act (Transportation)

- Regulations on Safety of General High Pressure Gas

Article 48 of the Regulations (Security Measures and Technical Standards Pertaining to Transportation)
--

Article 49 of the Regulations (Technical Standards, etc. for Transportation Using Containers Fixed to Vehicles)

Article 50 of the Regulations (Technical Standards, etc. for Transportation in Other Cases)

- Regulations on Safety of Liquefied Petroleum Gas

Article 47 of the Regulations (Security Measures and Technical Standards Pertaining to Transportation)
--

Article 48 of the Regulations (Technical Standards, etc. for Transportation Using Containers Fixed to Vehicles)

Article 49 of the Regulations (Technical Standards, etc. for Transportation in Other Cases)

- Article 48 of the Act (Filling)

- Regulations on Safety of Containers

Article 19 of the Regulations (Accessories for Containers Other than Non-refillable Containers)

Article 21 of the Regulations (Standards for Processing Containers)

3) Explosives Control Act [Ministry of Economy, Trade and Industry]

- Article 19 of the Act (Transport)

- Article 20 of the Act (Carrying a Certificate of Transportation of Explosives)

- Cabinet Office Ordinance on Transportation of Explosives (Reference Ordinance)

Article 12 of the Ordinance (Loading Method)
--

Articles 13 and 14 of the Ordinance (Prohibition of Mixed Loading)
--

Article 15 of the Ordinance (Method of Transportation)
--

Article 16 of the Ordinance (Signs)

Article 17 of the Ordinance (Route)

Article 18 of the Ordinance (Points to be Noted by the Shipper, etc.)

4) Poisonous and Deleterious Substances Control Act [Ministry of Health, Labour and Welfare]

- Article 7 of the Act (Handlers of Poisonous and Deleterious Substances)

- Article 8 of the Act (Qualifications to Be a Handler of Poisonous and Deleterious Substances)

- Article 11 of the Act (Handling of Poisonous Substances and Deleterious Substances)

- Article 16-2 of the Act (Measures to be Taken at the Time of an Accident)

- Article 22 of the Act, Article 41 of the Ordinance (Filing of Notifications by Persons Handling Poisonous Substances or Deleterious Substances in Their Business)

- Order for Enforcement of the Poisonous and Deleterious Substances Control Act

Article 40-3 of the Order (Use of Containers or Packages)

Article 40-4 of the Order (Mode of Loading)

Article 40-5 of the Order (Method of Transportation)
--

Article 40-6 of the Order (Obligation to Notify the Shipper)
--

Appendix 5

Occurrence of Accidents in Land Transportation of International Maritime Containers

Occurrence of Rollover and Falling Accidents Involving Container Trailers

		Import container	Export container	Total	Fatalities
Total number of accidents in 2006-2015		64	40	104	17
Cause of accident	Overload	6	1	7	2
	Confirmed unbalanced load	7	0	7	1

Notes:

- Accidents that occurred between January 2006 and December 2015, reported in accordance with the Automobile Accident Reporting Regulations (including some preliminary reports).
- The type of accident is "rollover/fall" or "off the road."
- Among the causes of accidents, the presence or absence of unbalanced load is listed only for those that were confirmed by the Regional Transport Bureau.